



Fleet Claims Assistance Form

PART A: Record the details of the accident and keep these pages.

At the scene of the accident Follow this 5 step procedure:

- During office hours of 9am-5pm (Mon-Fri) please contact us on 0115 973 7302. Out of office hours please call 0800 822 3187 for 24/7 motor claims reporting.
- Take photographs of any damage to vehicles and the scene of the accident provided it is safe and appropriate to do so.
- Record all incident details on the form below.
- Give the Attached page to the driver of the other vehicle (the Third Party).
- Get details of any witnesses.

Your Company Name is:

Date of Accident:

Weather conditions:

Number of Passengers: Male Adults: Female Adults: Male Children: Female Children:

Was an Ambulance called? Yes No Did the Police Attend? Yes No

Driver of the other Vehicle (The Third Party) Details:

Name of Third Party (Person or Company):

Owner of Vehicle (Person or Company): Drivers Name:

Make and Model of Vehicle:

Third Party Policy Number:

Third Party Email Address:

Third Party Address:

Witness Details:

Name of Witness:

Mobile/Contact Number:

Your Details:

Your name:

Registration Number:

Mobile/Contact Number:

Show Damage to the Vehicles (please attach pictures of cars):

YOUR VEHICLE:

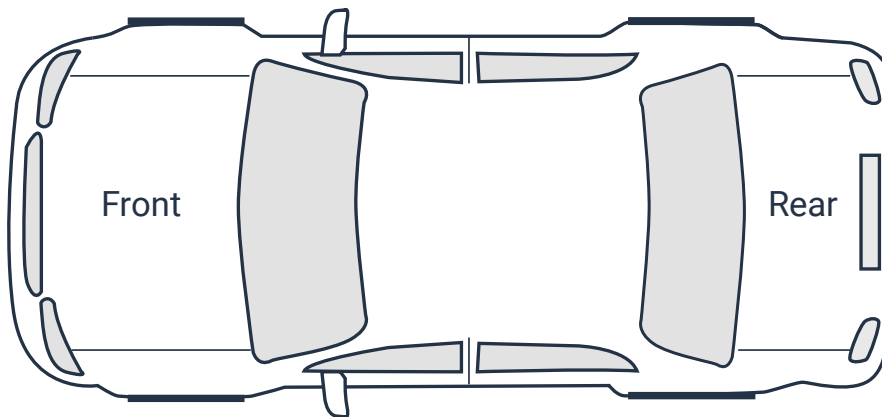

THIRD PARTY VEHICLE:

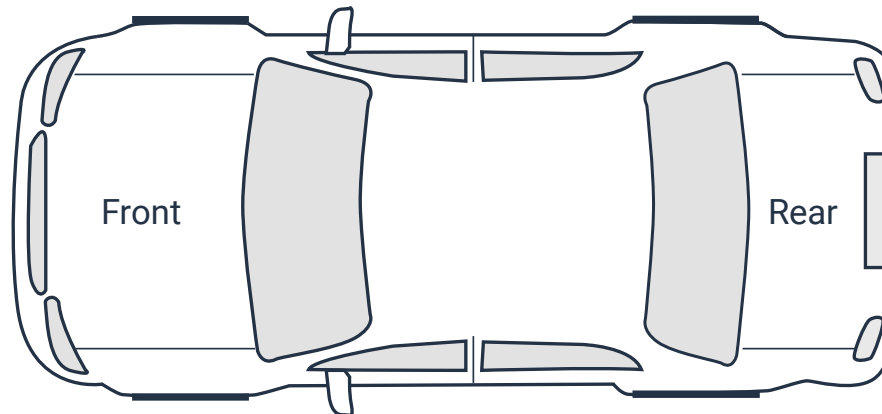



routen chaplin.

Fleet Claims Assistance Third Party Form

PART B: To be handed to the Third Party

Please call during office hours of 9am-5pm (Mon-Fri) please contact us on 0115 973 7302. Out of office hours please call 0800 822 3187 for 24/7 motor claims reporting if you consider our insured to be at fault. Where there is no dispute over liability, we could deal with your claim faster than your own insurer.

Our Drivers Company:

Our Drivers Company Policy Number:

Please call during office hours of 9am-5pm (Mon-Fri) please contact us on 0115 973 7302. Out of office hours please call 0800 822 3187 for 24/7 motor claims reporting.

- The Driver of this Vehicle does not admit liability, whether written, spoken or implied.
- We politely remind you that it is your common law duty to keep your losses to a minimum.